

# 7750R Feed Gap Adjustment

Feed gap adjustment of the unit is always performed before shipment and optimized for US currency. However, feed gap adjustments may be required periodically. The rubber components in the feed mechanism will wear over time, causing the feed gap to get larger. This can lead to Double or Half Note errors. On the other hand, if the feed gap is adjusted to tight, this can lead to Chain error or bill jamming.

## STEPS

Follow this procedure to adjust properly the feed gap, you will need a Philips-Head screwdriver (not included with the unit).

1. Ensure the machine is turned off.
2. Locate the feed gap adjustment knob (red) and the fixing plate screw (red arrows).
3. Loosen (counterclockwise) the fixing plate screw before adjusting feed gap adjustment knob.

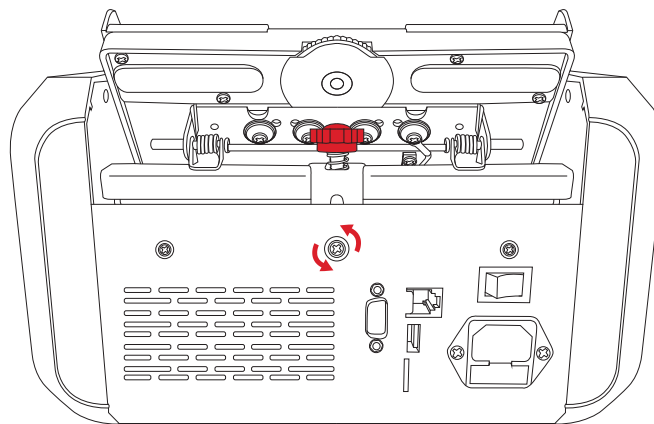

4. If more than one bill is being pulled into the feed mechanism a "Double" or "Half" Note error will appear on screen. Turn the knob clockwise to decrease the feed gap. Adjust 1 turn, then re-test the machine to see if the problem is corrected. Repeat if necessary.

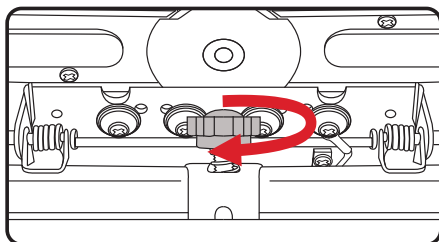

## NOTE:

If the feed gap is adjusted too narrow, Chain error, bill jams and tears can occur (see Step 5).

# 7750R Feed Gap Adjustment

5. If the feed gap is adjusted too narrow, a "Chain" Error, or "Jam" Error will appear on screen, a narrow feed gap can also potentially tear bills. Turn the knob counterclockwise to increase the feed gap. Adjust 1 turn, then re-test the machine to see if the problem is corrected. Repeat if necessary.

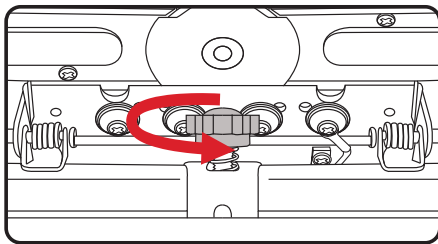

**NOTE:**

If the feed gap is adjusted too wide, Double and Hall Note errors can occur (see Step 4).

6. Secure the adjusted position by tightening (clockwise) the fixing plate screw.

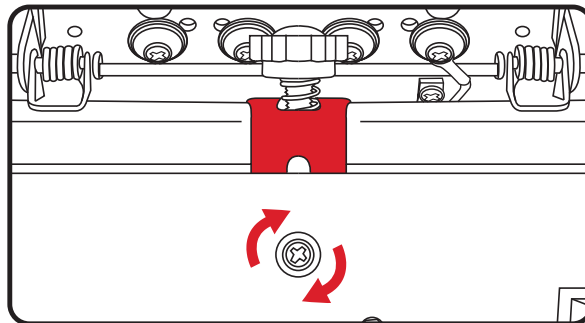

**NOTE:**

Several factors can cause a Cassida 7750R to jam and not recognize genuine bills:

- Improper loading
- Feed gap not adjusted properly
- Overly wrinkled, overly creased, and overly worn, and vandalized bills
- Foreign objects dropped or run through the bill path
- Dropping the unit or bumping into the unit during use
- A harsh change in temperature

**CONTACT INFORMATION**

Cassida Corporation  
After Market Technical Services  
Support: <http://www.cassidausa.com/support>  
E-Mail: [support@cassidausa.com](mailto:support@cassidausa.com)